

LOW POWER NPN SILICON TRANSISTOR

Qualified per MIL-PRF-19500/391

Devices

2N3019	2N3057A	2N3700
2N3019S		2N3700S

Qualified Level

JAN
JANTX
JANTXV
JANS

MAXIMUM RATINGS

Ratings	Symbol	Value	Units
Collector-Emitter Voltage	V_{CEO}	80	Vdc
Collector-Base Voltage	V_{CBO}	140	Vdc
Emitter-Base Voltage	V_{EBO}	7.0	Vdc
Collector Current	I_C	1.0	Adc
Total Power Dissipation @ $T_A = +25^{\circ}C^{(1)}$	P_T	2N3019; 2N3019S	0.8
2N3057A		0.4	
2N3700		0.5	
2N3700UB		0.4	
@ $T_C = +25^{\circ}C^{(2)}$		2N3019; 2N3019S	5.0
2N3057A	1.8		
2N3700	1.8		
2N3700UB	1.16		
Operating & Storage Jct Temp Range	T_J, T_{stg}	-55 to +175	$^{\circ}C$

- Derate linearly 4.6 mW/ $^{\circ}C$ for type 2N3019 and 2N3019S; 2.3 mW/ $^{\circ}C$ for type 2N3057A; 2.85 mW/ $^{\circ}C$ for type 2N3700; 6.6 mW/ $^{\circ}C$ for type 2N3700UB for $T_A \geq +25^{\circ}C$.
- Derate linearly 28.6 mW/ $^{\circ}C$ for type 2N3019 and 2N3019S; 10.3 mW/ $^{\circ}C$ for types 2N3057A, 2N3700, & 2N3700UB for $T_C \geq +25^{\circ}C$.

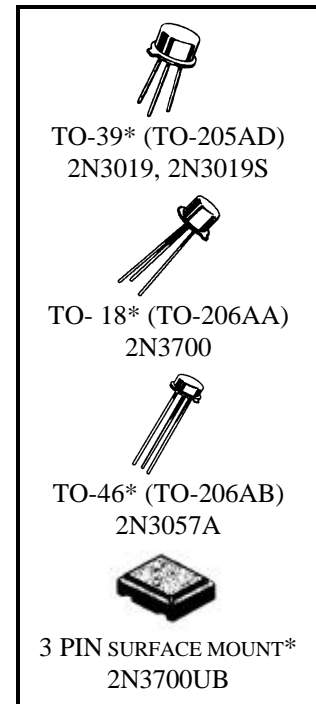

*See appendix A for package outline

ELECTRICAL CHARACTERISTICS ($T_A = 25^{\circ}C$ unless otherwise noted)

Characteristics	Symbol	Min.	Max.	Unit
Collector-Base Breakdown Voltage $I_C = 100 \mu A_{dc}$	$V_{(BR)CBO}$	140		Vdc
Emitter-Base Breakdown Voltage $I_E = 100 \mu A_{dc}$	$V_{(BR)EBO}$	7.0		Vdc
Collector-Emitter Breakdown Current $I_C = 30 mA_{dc}$	$V_{(BR)CEO}$	80		Vdc

ELECTRICAL CHARACTERISTICS (con't)

Characteristics	Symbol	Min.	Max.	Unit
-----------------	--------	------	------	------

OFF CHARACTERISTICS (con't)

Collector-Emitter Cutoff Current $V_{CE} = 90 \text{ Vdc}$	I_{CES}		10	ηAdc
Emitter-Base Cutoff Current $V_{EB} = 5.0 \text{ Vdc}$	I_{EBO}		10	ηAdc

ON CHARACTERISTICS (1)

Forward-Current Transfer Ratio $I_C = 150 \text{ mAdc}, V_{CE} = 10 \text{ Vdc}$ $I_C = 0.1 \text{ mAdc}, V_{CE} = 10 \text{ Vdc}$ $I_C = 10 \text{ mAdc}, V_{CE} = 10 \text{ Vdc}$ $I_C = 500 \text{ mAdc}, V_{CE} = 10 \text{ Vdc}$ $I_C = 1.0 \text{ Adc}, V_{CE} = 10 \text{ Vdc}$	h_{FE}	100 50 90 50 15	300 200 200	
Collector-Emitter Saturation Voltage $I_C = 150 \text{ mAdc}, I_B = 15 \text{ mAdc}$ $I_C = 500 \text{ mAdc}, I_B = 50 \text{ mAdc}$	$V_{CE(sat)}$		0.2 0.5	Vdc
Base-Emitter Saturation Voltage $I_C = 150 \text{ mAdc}, I_B = 15 \text{ mAdc}$	$V_{BE(sat)}$		1.1	Vdc

DYNAMIC CHARACTERISTICS

Small-Signal Short-Circuit Forward Current Transfer Ratio $I_C = 1.0 \text{ mAdc}, V_{CE} = 5.0 \text{ Vdc}, f = 1.0 \text{ kHz}$	h_{fe}	80	400	
Magnitude of Small-Signal Short-Circuit Forward Current Transfer Ratio $I_C = 50 \text{ mAdc}, V_{CE} = 10 \text{ Vdc}, f = 20 \text{ MHz}$	$ h_{fe} $	5.0	20	
Output Capacitance $V_{CB} = 10 \text{ Vdc}, I_E = 0, 100 \text{ kHz} \leq f \leq 1.0 \text{ MHz}$	C_{obo}		12	p^f
Input Capacitance $V_{EB} = 0.5 \text{ Vdc}, I_C = 0, 100 \text{ kHz} \leq f \leq 1.0 \text{ MHz}$	C_{ibo}		60	pF

SAFE OPERATING AREA

DC Tests $T_C = 25^{\circ}\text{C}, 1 \text{ Cycle}, t = 10 \text{ ms}$	
Test 1 2N3019, 2N3019S 2N3057A, 2N3700, 2N3700UB	$V_{CE} = 10 \text{ Vdc}$ $I_C = 500 \text{ mAdc}$ $I_C = 180 \text{ mAdc}$
Test 2 2N3019, 2N3019S 2N3057A, 2N3700, 2N3700UB	$V_{CE} = 40 \text{ Vdc}$ $I_C = 125 \text{ mAdc}$ $I_C = 45 \text{ mAdc}$
Test 3 2N3019, 2N3019S 2N3057A, 2N3700, 2N3700UB	$V_{CE} = 80 \text{ Vdc}$ $I_C = 60 \text{ mAdc}$ $I_C = 22.5 \text{ mAdc}$

(1) Pulse Test: Pulse Width = 300 μs , Duty Cycle $\leq 2.0\%$.